

1200Mbps 11ac High Power Ceiling Mount AP

WHAT DOES THIS PRODUCT DO?

AP-WAC2100-V2 is an 11ac Wi-Fi standard Realtek Chipset high power Ceiling Wireless Access Point support 11ac combined 1200Mbps Wi-Fi speed over 2.4GHz(300Mbps) and 5GHz(900Mbps), Gigabit WAN port, make more wireless users can access into it. It is an economic option for hotels, schools, restaurants, or other enterprise places.

QUICK OVERVIEW

- Comply with IEEE 802.11ac/b/g/n, dual-band.
- 1200Mbps Data Rate, 2x2 MIMO Technology.
- 1*100/1000Mbps WAN Port, 1*100/1000Mbps LAN Port, faster Ethernet.
- Support active IEEE 802.3af 48V PoE standard.
- Support SSID broadcasting, Multi SSID up to 8 (4 SSID in 2.4GHz, 4 SSID in 5GHz).
- Support Gateway (PPPOE, static IP, dynamic IP), Wireless AP, Repeater, WISP operation mode in FAT AP.
- With the function of the built-in firewall, IP filter, URL filter, and MAC filter.
- Comply with IEEE 802.3az standard, RF power adjustment, and frequency analyzer for better application in different environments.



KEY FEATURES AND HIGHLIGHTS

FIT/FAT Operation Mode :-

- AP-WAC2100-V2 support FIT/FAT operation mode;
- FIT AP mode works with the AC controller, plug and play, central management by AC controller, mostly for enterprise application
- FAT AP mode supports AP, repeater, gateway, WISP operation mode, can be configured by GUI, suits for home mostly.

MU-MIMO Technology :-

- With MIMO technology, it adopts 256QAM modulation, supports MU-MIMO (Multi-User Multiple-Input Multiple-Output), 4 Spatial streams greatly improves communication efficiency.

Power over Ethernet :-

- AP-WAC2100-V2 has integrated IEEE802.3af Power over Ethernet (PoE), for easy installation and lower cost.

- So, it can be installed in areas where power outlets are not readily available, eliminating the mess of altering existing network infrastructure.

Zero Configurations :-

- Supports FIT/FAT AP together, works with Airpro WLAN Controller, configures IP address, ESSID, Channel, Password, upgrade firmware, backup, and restore.
- WLAN controller is easy for administrator access to do remote monitoring/management at any time and any place makes this AP and WLAN controller more professional and cost-effective in Wi-Fi Projects.

PRODUCT SPECIFICATIONS

Technical Specifications

Hardware:	AP-WAC2100-V2				
Chipset	RTL8197FH + RTL8812BRH + RTL8211F				
Standard	802.11ac/b/g/n, MIMO technology				
Memory	128MB DDR2 RAM				
Flash	16MB				
Interface	1 * 100Mbps RJ45 WAN Port 1 * 100Mbps RJ45 LAN Port 1 * Reset button, press 15 seconds to revert to the default setting				
Antenna	Built-in 5dBi MIMO Antenna				
Power consumption	48V PoE<12W				
Size	168mm * 168 mm * 32 mm				
RF Data					
Frequency	2.4G: 802.11b/g/n: 2.4GHz~2484GHz 5GHz: 802.11a/n/ac: 5150MHz ~5850MHz				
Country code	FCC, IC, ETSI, MKK, MKK1, MKK2, MKK3, NCC, RUSSIAN, CN				
Modulation	OFDM = BPSK, QPSK, 16-QAM, 64-QAM, 128-QAM DSSS = DBPSK, DQPSK, CCK				
Throughput	1200Mbps				
RF Power (2.4GHz)	802.11b	11M	17±2dBm	1M	20±2dBm
	802.11g	54M	16±2dBm	6M	19±2dBm
	802.11n Ht20	MCS7	15±2dBm	MCS0	18±2dBm
	802.11n HT40	MCS7	15±2dBm	MCS0	18±2dBm
RF Power (5GHz)	802.11a	54M	17±2dBm	6M	19±2dBm
	802.11n HT20	MCS7	16±2dBm	MCS0	18±2dBm
	802.11n HT40	MCS7	15±2dBm	MCS0	17±2dBm
	802.11ac HT80	MCS9	14±2dBm	MCS0	16±2dBm
Receive Sensitivity (2.4GHz)	802.11b	11M	-85dBm	1M	-94dBm
	802.11g	54M	-72dBm	6M	-88dBm
	802.11n HT20	MCS7	-70dBm	MCS0	-86dBm
	802.11n HT40	MCS7	-68dBm	MCS0	-85dBm
Receive Sensitivity (5GHz)	802.11a	54M	-72dBm	6M	-90dBm
	802.11n HT20	MCS7	-70dBm	MCS0	-88dBm
	802.11n HT40	MCS7	-68dBm	MCS0	-86dBm
	802.11ac Ht80	MCS9	-58dBm	MCS0	-85dBm
EVM	2.4G: 802.11b: ≤-10 dB; 802.11g: ≤-25 dB; 802.11n: ≤-28 dB 5G: 802.11a: ≤-25 dB; 802.11n: ≤-28 dB; 802.11ac: ≤-32 dB				
PPM	±20ppm				
Wi-Fi Users	Up to 100				
Firmware Features:					
Operation mode	Wireless AP, Gateway, WISP, Wi-Fi Repeater				
WAN Type	Dynamic IP/Static IP/PPPoE/L2TP (Dual Access) /PPTP (Dual Access)				
SSID	Multiple SSID (4 SSID for 2.4G, 4 SSID for 5.8G)				
Firewall	DoS, SPI Firewall, IP Address Filter/MAC Address Filter/Domain Filter IP and MAC Address Binding				
Protocols	Ipv4				
Management	Firmware GUI, Remote Management, WLAN Controller				
Package Contents	1200Mbps Dual Band wireless access point Ethernet Cable Quick Installation Guide Setting Accessory				
System Requirements	Microsoft Windows 98SE, NT, 2000, XP, Vista™ or Windows 7, Windows 8, MAC OS, NetWare, UNIX, or Linux				
Environment	Operating Temperature: -20~55 Storage Temperature: -40~70 Humidity: 5%~95% non-condensing; Storage Humidity: 5%~90% non-condensing				

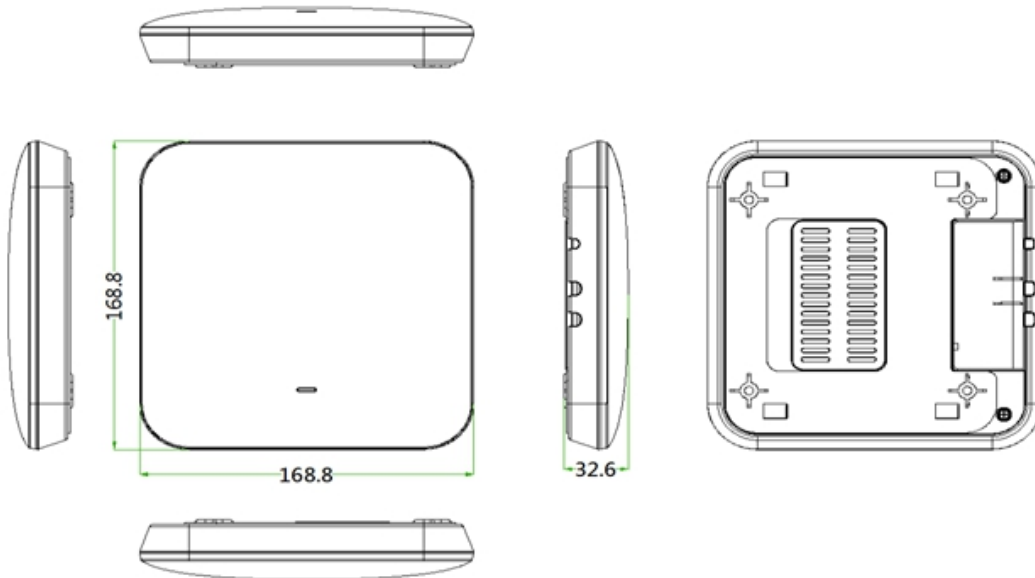
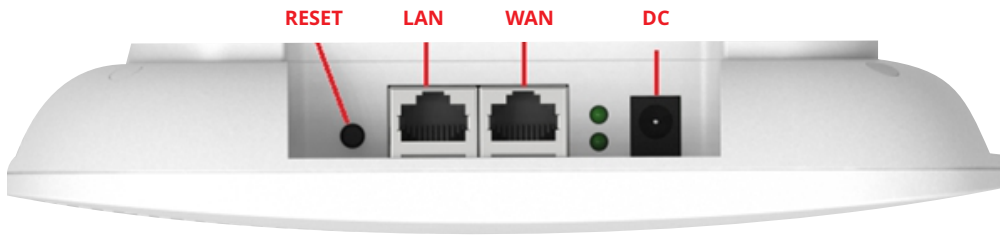

www.airpro.in